

TDS Model B4A123H

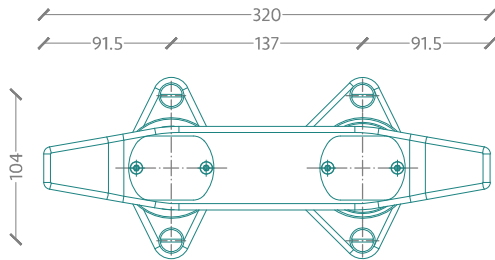

DIMENSIONS



PLANT

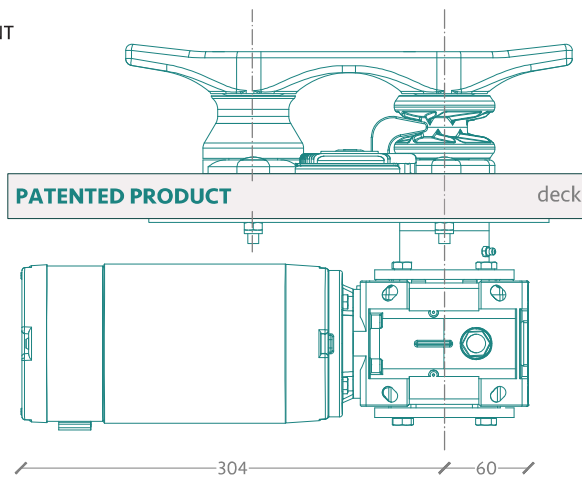

LONGITUDINAL SECTION

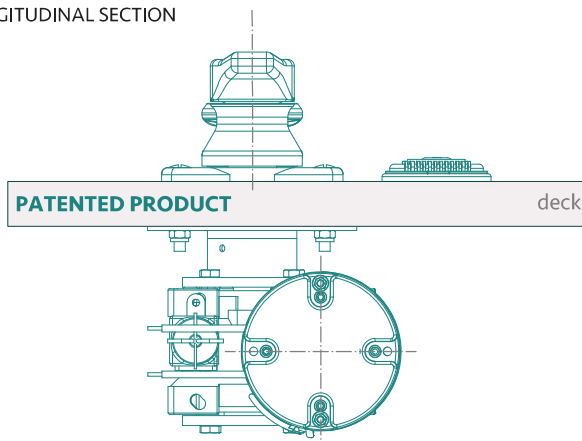

TRASVERSAL SECTION

TECHNICAL DATA

| | |
|-----------------------------------|----------------------------|
| Model | B4A123H |
| Rated Voltage In | 12 VDC |
| Power | 550 W |
| Rated Load Current | 57 A |
| Maximum Current Draw | 60 A |
| Duty Cycle | S2 30 min |
| IP Rating (Motor) | IP44 |
| Maximum Rope Speed | 8 M/Min |
| Output Shaft Speed | 60 RPM |
| Output Shaft Torque | 78 Nm |
| Load In Work On Gearbox | 3120 N- 318 kg |
| Maximum Load On Gearbox | 6240 N / 600-630 kg |
| Insulation Class | F |
| Gearbox Oil | Shell Omala S4WE |
| Tot Weight | 23 kg |
| Included Command | Single Way Footswitch |
| Material | Stainless Steel AISI 316 L |
| Mooring Line Section Range | 22mm - 30mm |
| Vessel Length (Suggested) | 45-70 ft/ 15-22 mt |
| Vessel Weight (Suggested) | 20-30 tons |

The Self Tailing Cleat