

TDS Model B1C241H

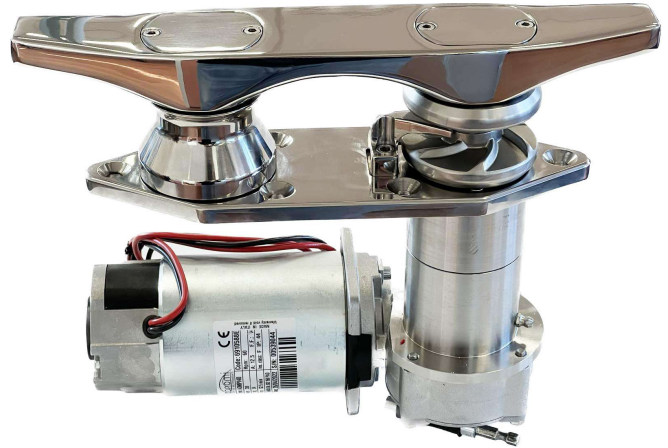

DIMENSIONS

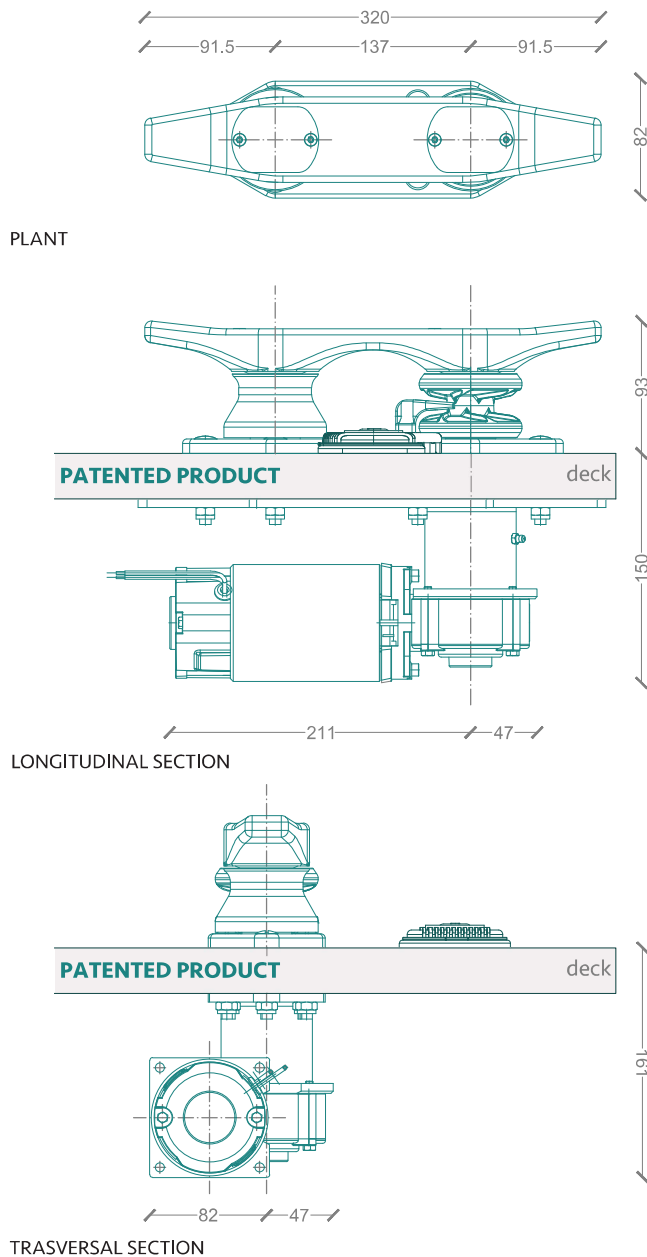

TECHNICAL DATA

| | |
|-----------------------------------|----------------------------|
| Model | B1C241H |
| Rated Voltage In | 24 VDC |
| Power | 230 W |
| Rated Load Current | 12,5 A |
| Maximum Current Draw | 40 A |
| Duty Cycle | S2 5 min |
| IP Rating (Motor) | IP44 |
| Maximum Rope Speed | 6,5 M/Min |
| Output Shaft Speed | 60 RPM |
| Output Shaft Torque | 25-30 Nm |
| Load In Work On Gearbox | 1078 N- 110 kg |
| Maximum Load On Gearbox | 1600 N/ 145-175 kg |
| Insulation Class | F |
| Gearbox Oil | ISO 150 PA0 |
| Tot Weight | 11,5 kg |
| Included Command | Single Way Footswitch |
| Material | Stainless Steel AISI 316 L |
| Mooring Line Section Range | 22mm - 30mm |
| Vessel Length (Suggested) | 40-45 ft/ 12-15 mt |
| Vessel Weight (Suggested) | 15-20 tons |

The Self Tailing Cleat