

TDS Model B3C121H

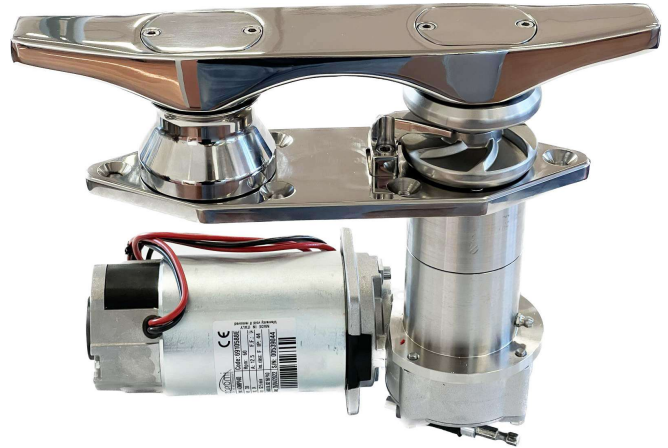

DIMENSIONS

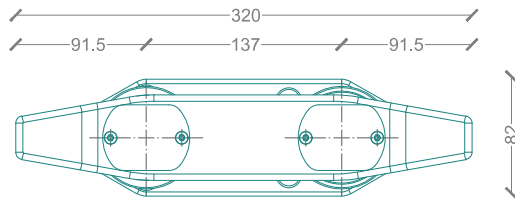

PLANT

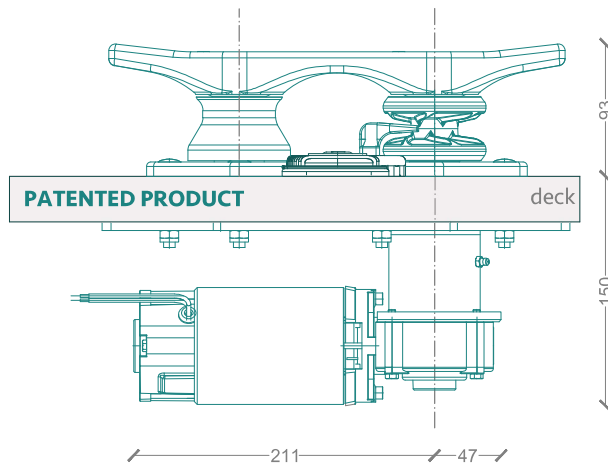

LONGITUDINAL SECTION

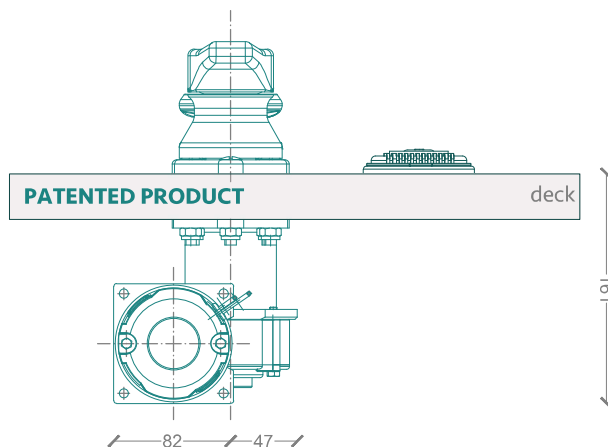

TRASVERSAL SECTION

TECHNICAL DATA

Model	B3C121H
Rated Voltage In	12 VDC
Power	230 W
Rated Load Current	25 A
Maximum Current Draw	40 A
Duty Cycle	S2 5 min
IP Rating (Motor)	IP44
Maximum Rope Speed	6,5 M/Min
Output Shaft Speed	60 RPM
Output Shaft Torque	25-30 Nm
Load In Work On Gearbox	1100 N - 110 kg
Maximum Load On Gearbox	1600 N / 145-175 kg
Insulation Class	F
Gearbox Oil	ISO 150 PAO
Tot Weight	11,5 kg
Included Command	Single Way Footswitch
Material	Stainless Steel AISI 316 L
Mooring Line Section Range	22mm - 30mm
Vessel Length (Suggested)	40-45 ft/ 12-15 mt
Vessel Weight (Suggested)	15-20 tons

The Self Tailing Cleat