

TDS Model B6A248H

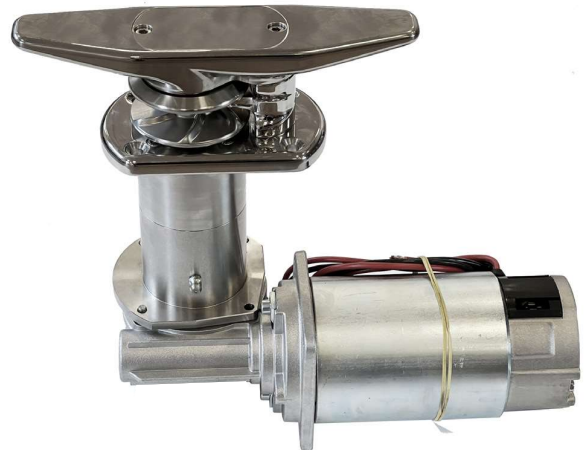

DIMENSIONS

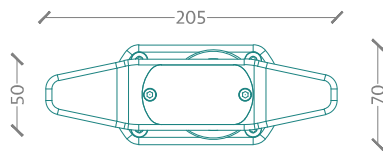

PLANT

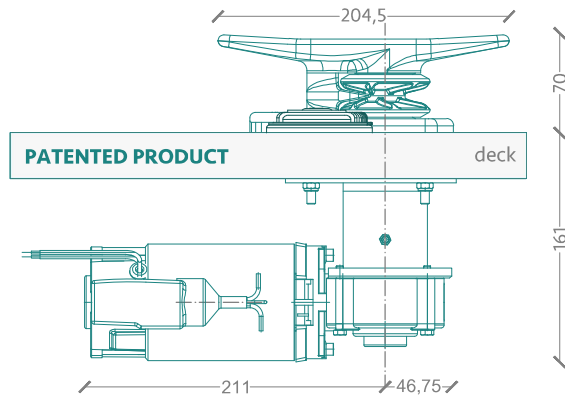

LONGITUDINAL SECTION

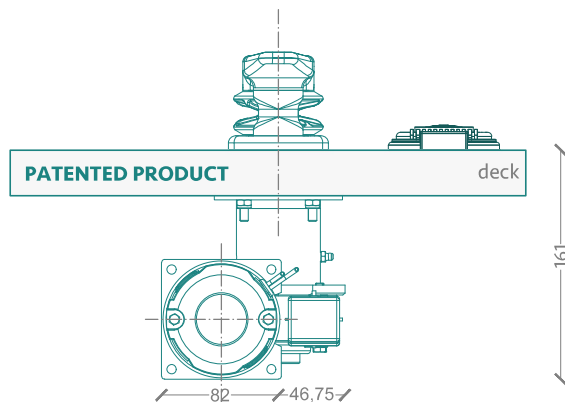

TRASVERSAL SECTION

TECHNICAL DATA

Model	B6A248H
Rated Voltage In	24 VDC
Power	230 W
Rated Load Current	12,5 A
Maximum Current Draw	40 A
Duty Cycle	S2 5 min
IP Rating (Motor)	IP44
Maximum Rope Speed	6,5 M/Min
Output Shaft Speed	60 RPM
Output Shaft Torque	25-30 Nm
Load In Work On Gearbox	800 N / 80-85 kg
Maximum Load On Gearbox	1370-1570 N - 160-200 kg
Insulation Class	F
Gearbox Oil	ISO 150 PAO
Tot Weight	6 Kg
Included Command	Single Way Footswitch
Material	Stainless Steel AISI 316 L
Mooring Line section Range	15mm - 20mm
Vessel Length (Suggested)	30-40 ft / 9-12 mt
Vessel Weight (Suggested)	10-15 tons

The Self Tailing Cleat