

# TDS Model B2B124H

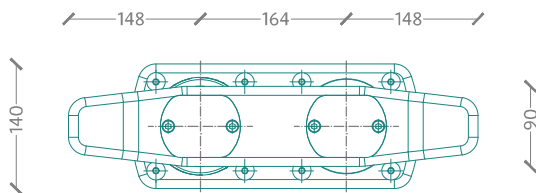

## DIMENSIONS



PLANT

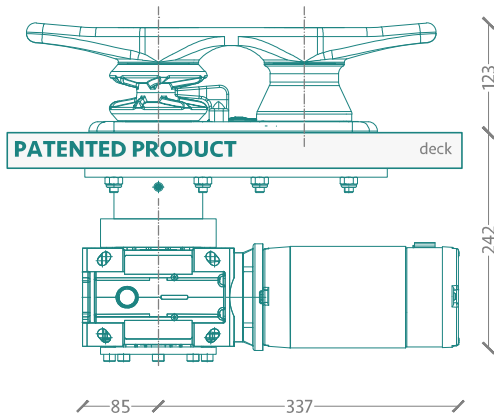

LONGITUDINAL SECTION

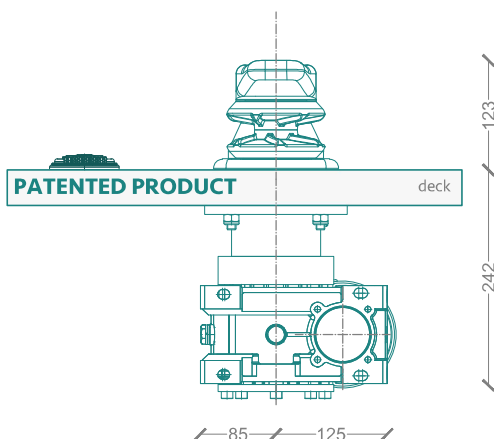

TRASVERSAL SECTION

## TECHNICAL DATA

<b>Model</b>	B2B124H
<b>Rated Voltage In</b>	12 VDC
<b>Power</b>	550 W
<b>Rated Load Current</b>	57 A
<b>Maximum Current Draw</b>	60 A
<b>Duty Cycle</b>	S2 30 min
<b>IP Rating (Motor)</b>	IP44
<b>Maximum Rope Speed</b>	4,7 M/Min
<b>Output Shaft Speed</b>	60 RPM
<b>Output Shaft Torque</b>	78 Nm
<b>Load In Work On Gearbox</b>	4000 N / 400-410 kg
<b>Maximum Load On Gearbox</b>	7848 N - 800 kg
<b>Insulation Class</b>	F
<b>Gearbox Oil</b>	ISO 150 PAO
<b>Maximum current absorbed</b>	60 A
<b>Tot Weight</b>	52 Kg
<b>Included Command</b>	B60C124V
<b>Material</b>	AISI 316 L
<b>Mooring Line Section Range</b>	25mm-35mm
<b>Vessel Length (Suggested)</b>	70-95 ft / 22-30 mt
<b>Vessel Weight (Suggested)</b>	30-40 tons

The Self Tailing Cleat