



TDS Model B4C12V

DIMENSIONS

CONTROL BOX

FRONT SIDE

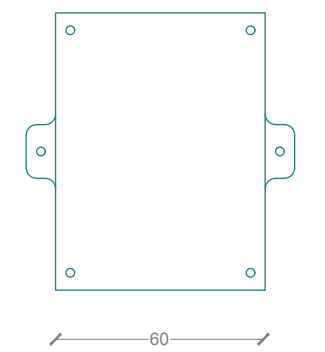

LATERAL SIDE

SINGLE SWITCH

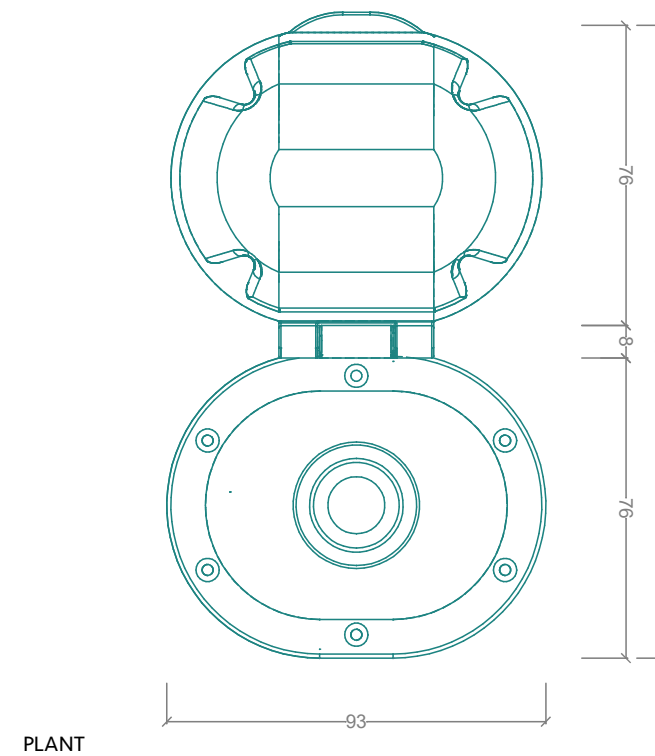

PLANT

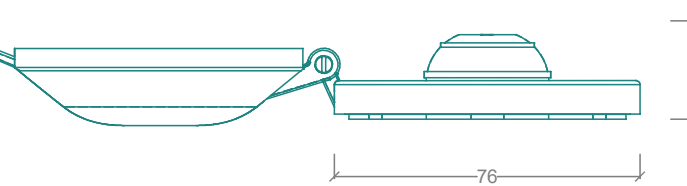

LATERAL SIDE



TECHNICAL DATA

Model	B4C12V
Power Supply Voltage	12VDC- 24VDC
Maximum Contact Voltage	200VDC- 140VDC
Contact Max Current Rating	10 A
IP Rating	IP68
Footswitch Wire Length	20cm
Switchbox Wire Length	1m
Switchbox Material	Plastic
Footswitch Material	Stainless Steel AISI 316 L
Tot Weight	0,2 kg

The product allows to:

This is a high-performance single footswitch is delivered to the customer with his control box and is able to activate any DC motor. The B4C12V provides a reliable and intuitive operation, allowing boaters to control their equipment safely and efficiently. With its suggested construction and advanced features, the product is the ideal solution for a wide range of marine applications.

Pay attention to the electrical connection the Single Switch - have only 10 mA
- never connect the switch without its control unit!

Single Switch